

DRIVER'S CONTROL CENTER DIFFERENTIAL CONTROL SYSTEM

WIRING SYSTEM

48.Driver's Control Center Differential Control System

A: SCHEMATIC

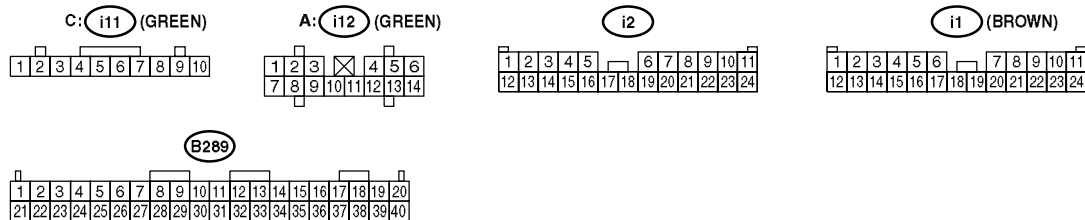
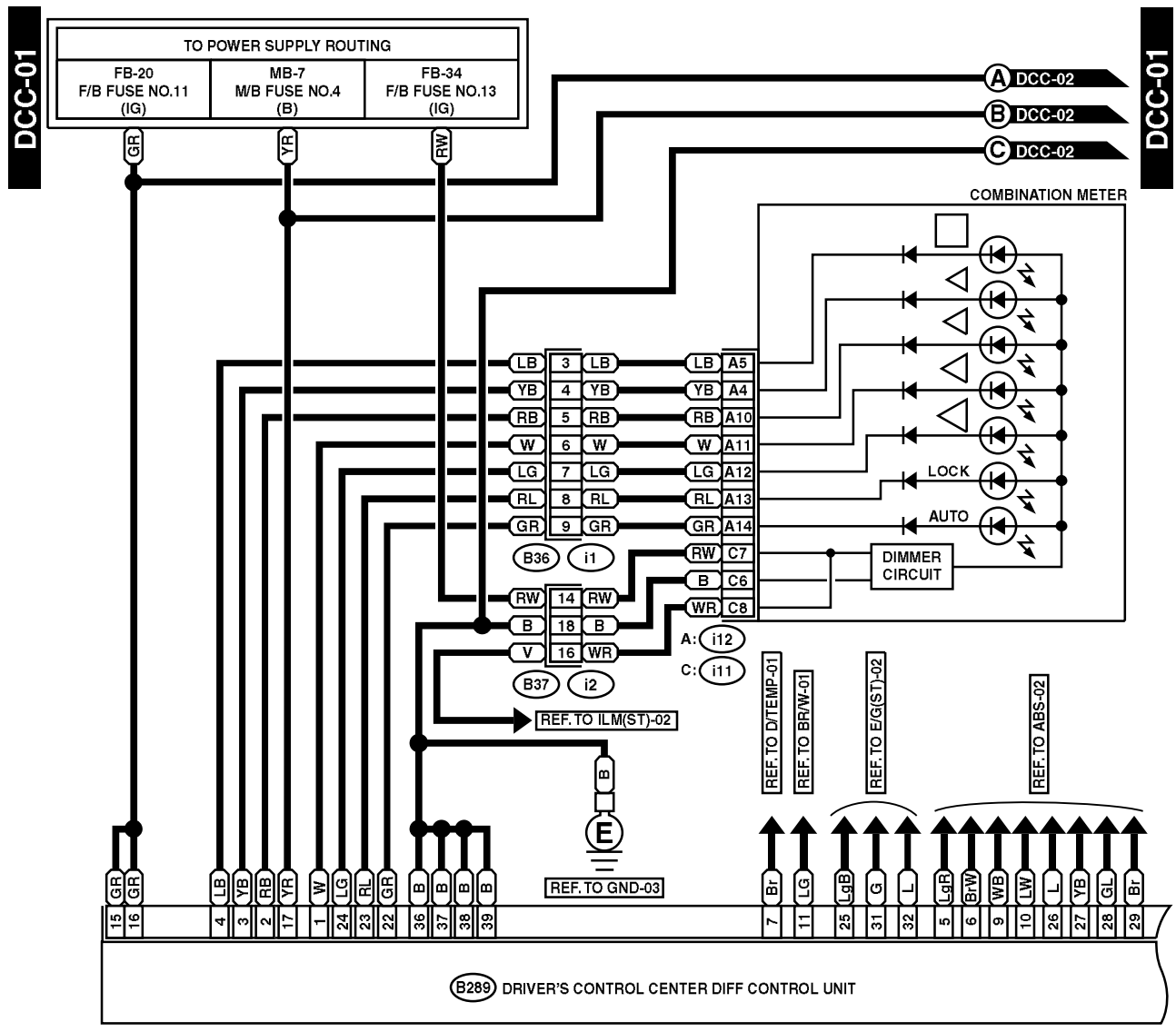

WI-02821

DRIVER'S CONTROL CENTER DIFFERENTIAL CONTROL SYSTEM

WIRING SYSTEM

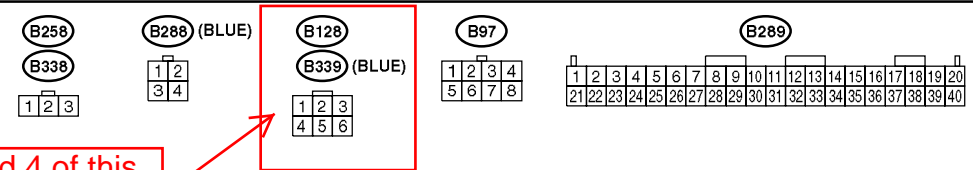
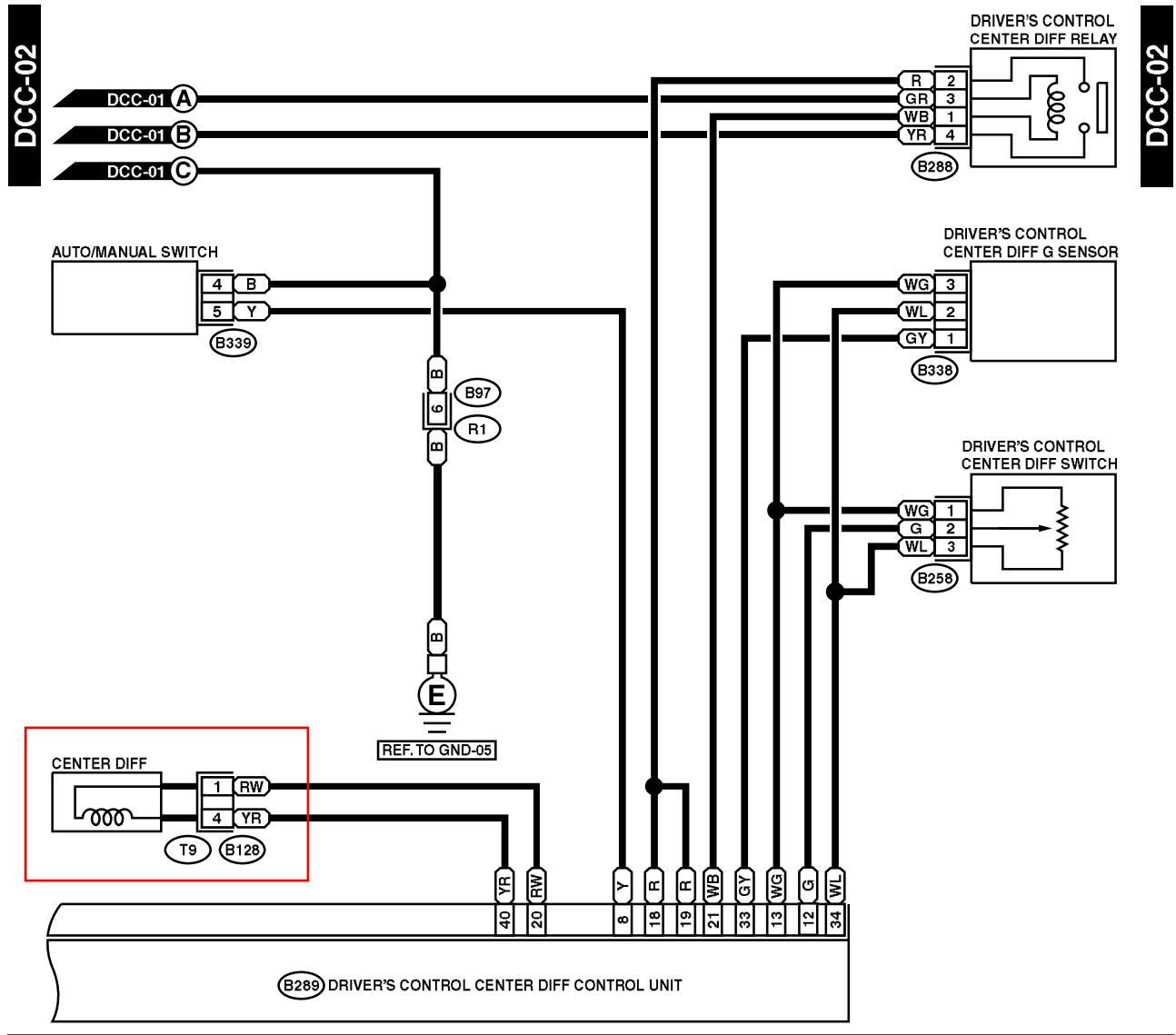

Pin 1 and 4 of this connector.

WI-02822